



Trenching Tools

Mini (.44", .55") / 19mm (.74") / 20mm (.76") / 22mm (.87")



ROAD REHABILITATION | DRILLING | TRENCHING

SOLID

Innovation Quality Service Value Application Expertise

The foundation for a successful trenching operation is built on rock-steady reliability and progress. Kennametal, the world's leading tooling and services provider, proudly introduces SOLID, our solution-focused platform that yields new levels of performance and productivity. SOLID-engineered tools deliver in the most challenging conditions.

**For unmatched quality, value, innovation, and application expertise,
make Kennametal your SOLID choice!**



	Item	Order Number	New Item	Collar Dia. (mm)	Shank Dia. (mm)	Puller Groove	Product Status	Recommended Application Chart / Conditions					Pieces per Box	Pieces per Pallet
								Soft Rock	Medium Rock	Hard Rock	Abrasive Rock	Laminated Rock		
SM / SD / SL Series	SM01	1010860		38	22	•	Stocked	•	•		•		50	2,500
	SM02	1010817		38	22	•	Stocked	•	•		•		50	2,500
	SM04	1317495		38	22	•	Stocked	•	•		•		50	2,500
	SM06	1010815		38	22	•	Stocked	•	•	•		•	50	2,500
	SM08	3663476	•	38	22		Stocked	•	•	•	•	•	50	2,500
	SD02	2504868		38	22	•	Made to Order	•	•		•		50	2,500
	SD04	2504865		38	22	•	Made to Order	•	•		•		50	2,500
	SD06	2504867		38	22	•	Made to Order	•	•	•		•	50	2,500
	SL02	1010797		27	22	•	Stocked	•	•		•		70	3,500
	SL04	1010795		27	22	•	Stocked	•	•	•		•	60	3,000
SL07	1809484		38	22		Stocked	•	•	•		•	40	3,000	
RL / RS Series	C3R	1010910		38	20		Stocked	•	•		•		40	2,000
	RS12	1010865		38	20	•	Stocked	•			•		50	2,500
	RS14	1156160		38	20	•	Stocked	•			•		50	2,500
	RS16	1156102		38	20	•	Stocked	•	•	•		•	50	2,500
	RS17	1156107	•	38	20	•	Stocked	•	•	•	•	•	50	2,500
	RS19	1991004		38	20	•	Stocked	•	•		•		50	2,500
	RL03	1010870		27	20	•	Stocked	•			•		75	3,750
	RL07	1010782		27	20	•	Stocked	•	•	•		•	50	3,500
	RL08	1010767		27	20	•	Stocked	•			•		75	3,750
	RL09	1010770		27	20	•	Stocked	•			•		75	3,750
	RL10	1010784		27	20	•	Stocked	•	•	•		•	75	3,750
RL11	1010772		27	20	•	Stocked	•					75	3,750	
C20 Series	C21	1010748		25	19	•	Stocked	•	•				75	3,750
	C21HD	1010789		25	19	•	Stocked	•	•	•		•	75	3,750
	C23	1010758		25	19	•	Stocked	•	•		•		75	3,750
	C21RHD	1010804		25	19		Stocked	•	•				60	3,000
	C21RFHD	1780648		38	19		Stocked	•	•	•		•	40	2,000
	C21F11NB	1253937		38	19	•	Stocked	•			•		50	2,500
	C21FHD	1253751		38	19	•	Stocked	•	•	•		•	50	2,500
Mini / Flat / Weld-On Series	CM42	1010778		19	11		Stocked	•	•		•		200	10,000
	CM61	1094015		19	14	•	Stocked	•	•				200	10,000
	CM63	1795208		25	14		Stocked	•	•		•		200	10,000
	CM65	1876905		25	14		Stocked	•	•		•		200	10,000
	DT50	1086101					Stocked	•	•	•			150	7,500
	DT87	1086378					Stocked	•	•	•			50	2,500
	RT1	1784646					Stocked	•	•	•			200	10,000
	RT2	1844257					Stocked	•	•	•			100	5,000

Proven Reliability – Unparalleled Productivity.

Wear Characteristics

Understanding and compensating for the different types of tip and body wear will help you make the most of your tool investment.

Wear Patterns

Steel Wash



exposed carbide



balanced wear

Shank Breakage



broken shank



worn block

Steel Wash / NB-Style Tip



maximum steel support



Back Bending



burr



broken hub

Thermal Cracking



spider web appearance

Balanced Wear



proper material size



balanced wear

Carbide Fracture



excessive fracture



deformed hole

SM Series / SD Series / SL Series

SM Series

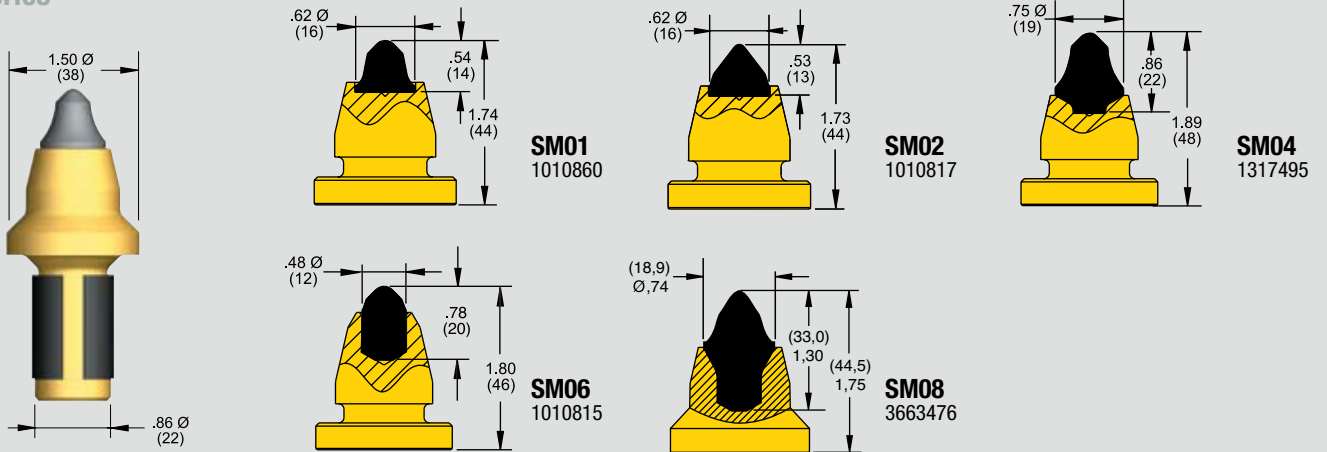

SD Series (Made to Order)

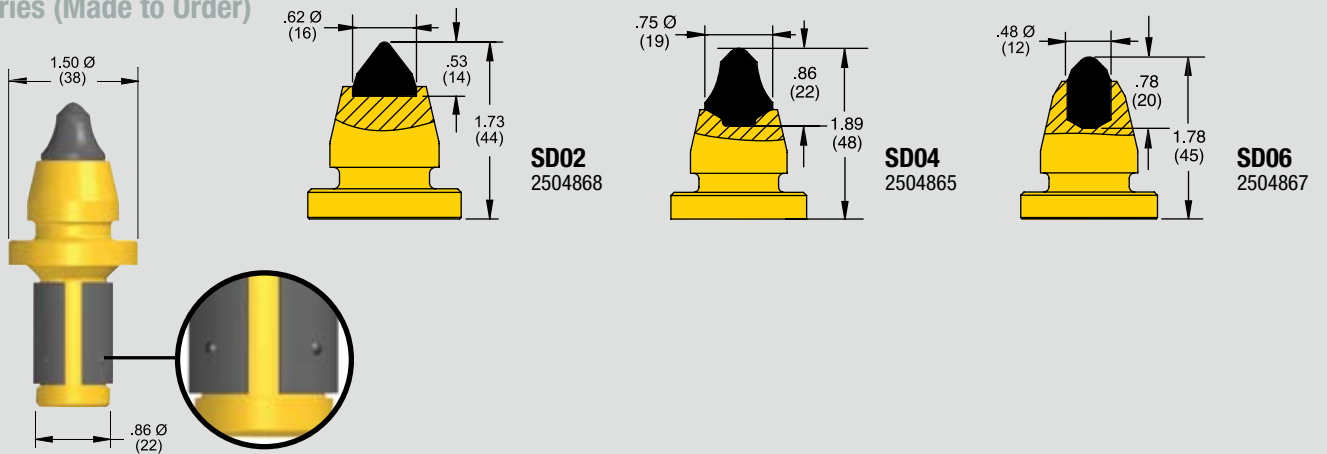

SL Series

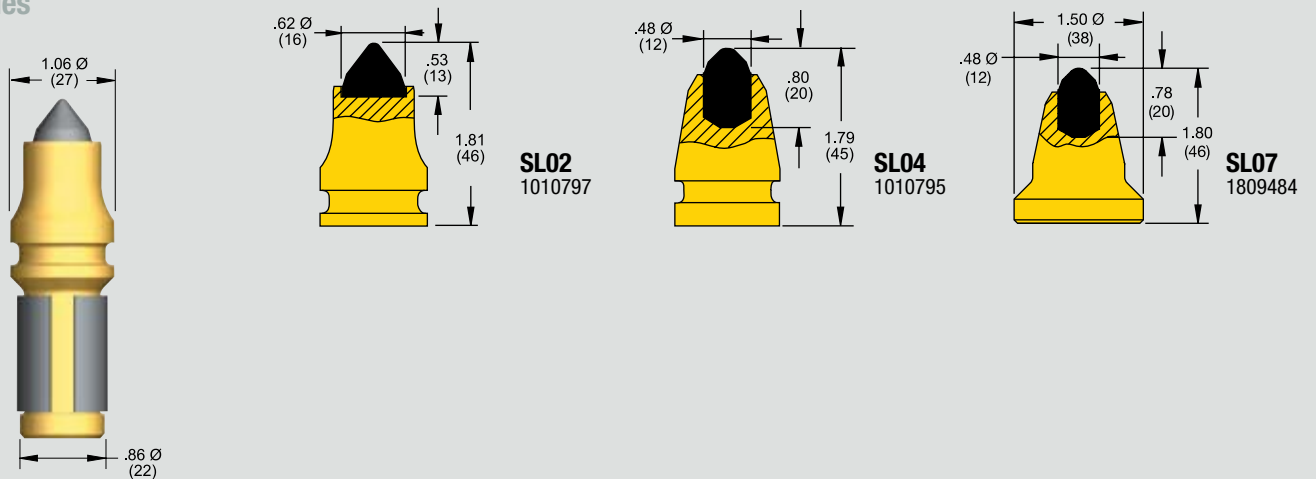

RL Series / RS Series / C20 Series

RL Series

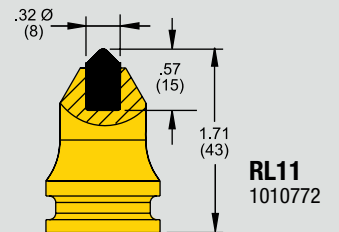
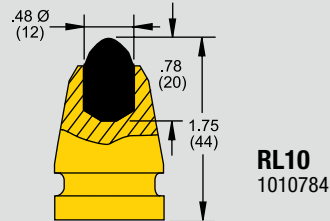
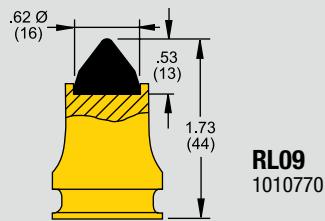
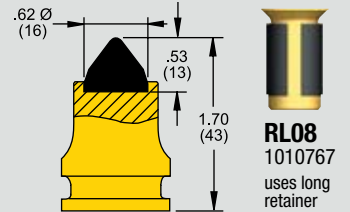
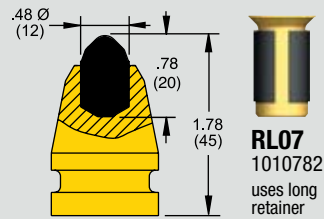
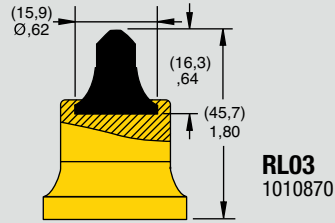

RS Series

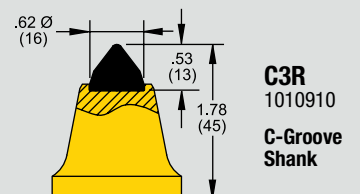
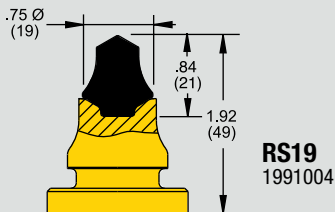
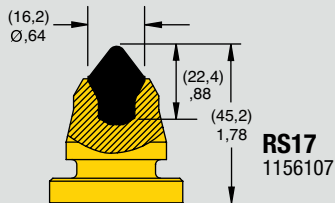
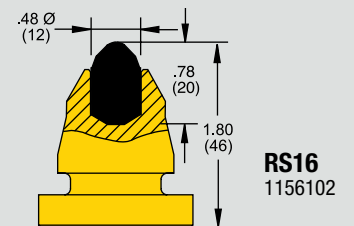
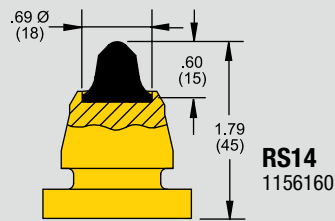
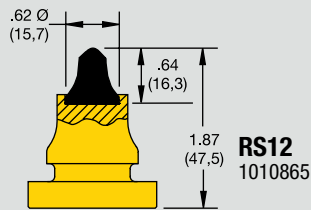
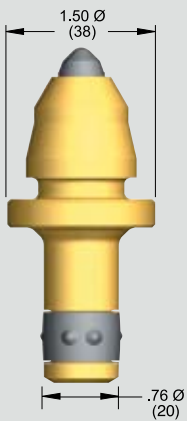

C20 Series

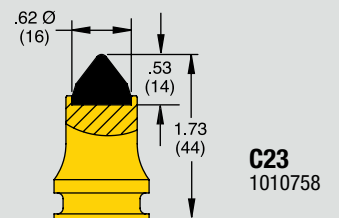
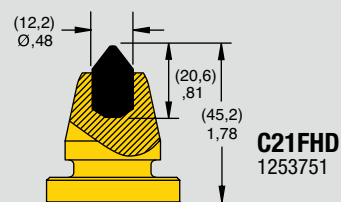
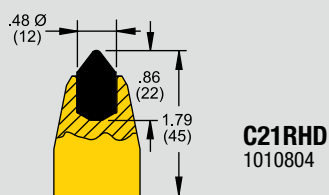
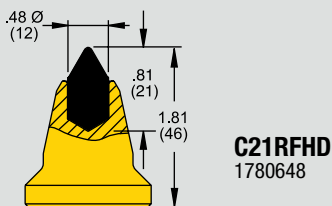
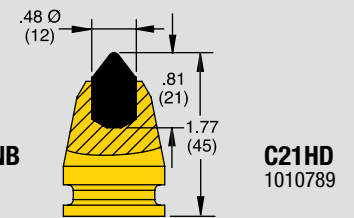
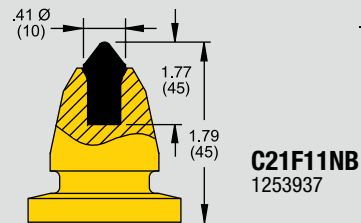
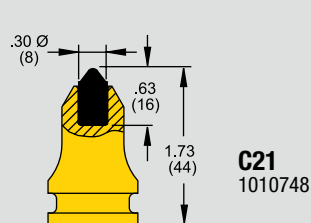
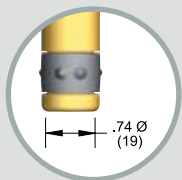

CM42
CM4 Retainer
 1012223



CM61 / 63
CM6L Retainer
 1595671



Mini Series / Flat Series / Weld-On Series

Mini Series

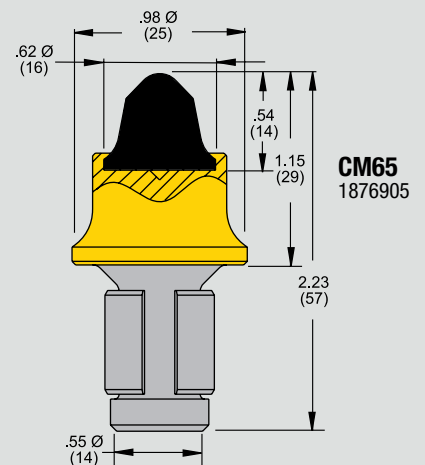
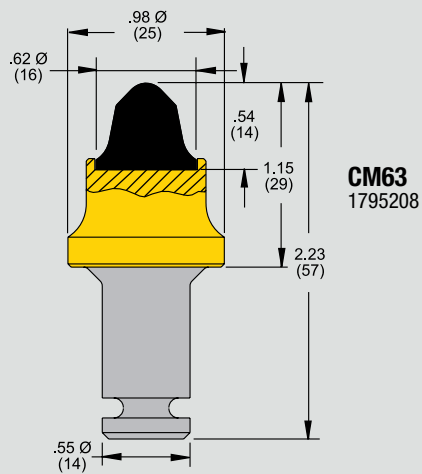
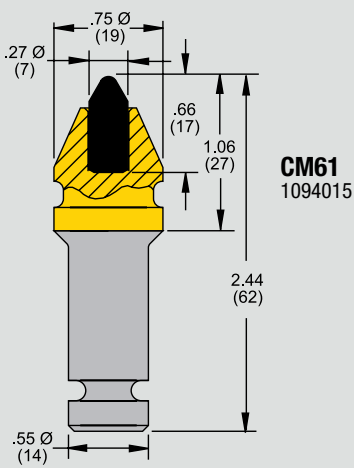
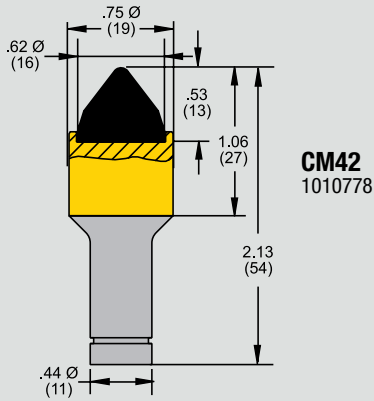

Flat / Weld-On Series

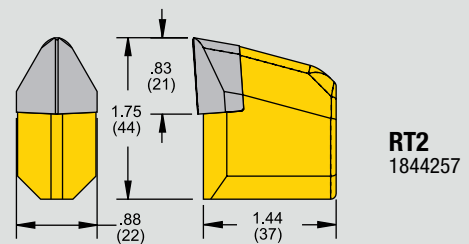
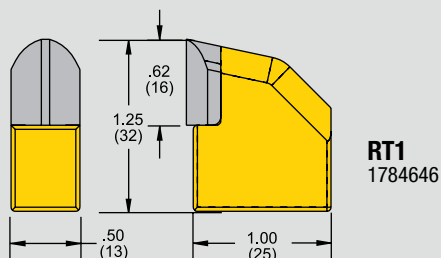
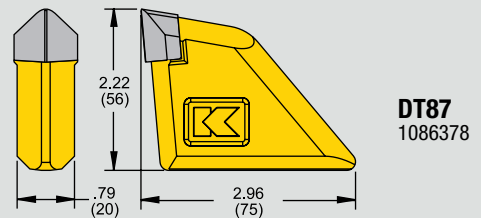
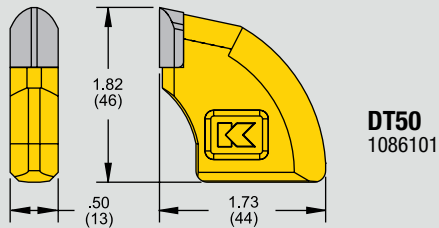

Kennametal

The proven global leader in the design, manufacture, implementation, and sale of premium-quality tooling systems for underground and surface mining, road rehabilitation, aggregates production, and waste recycling!

United States / Canada / Mexico

Phone: 800.458.3608

Fax: 800.521.3319

mcs-na.service@kennametal.com

Germany / European Served Area

Phone: (49) 6172 737 498

Fax: (49) 6172 737 42 453

mcs-ag.service@kennametal.com

Poland / Slovakia / Baltics

Phone: (48) 32 47 89 100

Fax: (48) 32 47 89 112

Brazil / Latin America

Phone: (55) 19 3936 9200

Fax: (55) 19 3936 9201

Argentina

Phone: (54) 011 4719 0700

Fax: (54) 011 4719 6116

Chile

Phone: (56) 2 2641177

Fax: (001) 888 442 4964

China

Phone: (86) 400 6501 388

Fax: (86) 10 8561 5263

Japan

Phone: (81) 3 3820 2855

Fax: (81) 3 3820 2800

Korea

Phone: (82) 2 2109 6967

Fax: (82) 2 2109 6981

Thailand / Singapore / Vietnam / Philippines

Phone: (66) 2642 3455

Phone: (66) 2246 8025 – 32

Fax: (66) 2641 2736 – 8

Malaysia / Indonesia

Phone: (6) 03 5569 9080

Fax: (6) 03 5569 0080

India

Phone: (91) 80 2839 4321

Phone: (91) 80 2219 8444

Fax: (91) 80 2839 1300

bangalore.information@kennametal.com

Australia / New Zealand

Phone: (61) 7 3801 5844

Fax: (61) 7 3801 5826

sydney.service@kennametal.com

South Africa / Sub Saharan Area

Phone: (27) 11397 3540

Fax: (27) 11397 3222



Kennametal Inc.
1600 Technology Way
Latrobe, PA 15650
USA

WWW.KENNAMETAL.COM